



Motorized Solutions Pty Ltd

Unit 2, 60 Box Road,
TAREN POINT NSW 2229

P: 02 9525 9588
E: sales@acdcms.com.au

AT-28 Electric Chain Actuator Adjustable Stroke 150mm-300mm



- Suitable for top-hinged windows, bottom-hinged windows and various applications
- Stroke adjustment selectable to 150mm, 200mm, 250mm or 300mm
- Stainless steel double link chain
- Push-pull force 250N available in operating voltage 24Vdc and 230Vac with current absorption
- External casing in zinc alloy and aluminium

Parameters	24V	220V
Voltage	DC24V±10%	DC24V±10%
Cutoff Current	0.6A	0.15A
Force	250N	250N
Speed	10mm/s	10mm/s
Temperature	-20-75 °C	-20-75 °C
Protection Class	IP32	IP32
Electric Connection	2 wires	3 wires + earth
Limit Stop	Electronic	Electronic

AT-28AC150-300MM250N

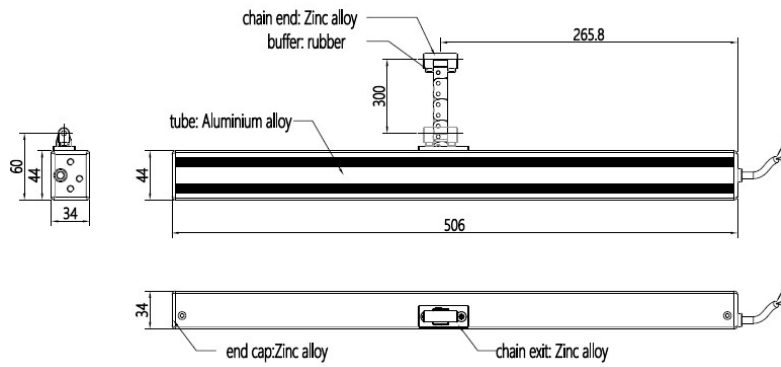

AT-28DC150-300MM250N

